

FOR-X

Model No.: XW-4012F

12inch High Performance Shallow woofer speaker for Car



Specifications

- * Stamped Steel frame with black painting
- * Paper cone with rubber surround
- * Convex IMPP Dust-cap
- * Hi-temp 2inch-4Layers Voice Coil
- * High efficiency Optimized FEA Motor
- * Stiff Poly-cot spider with round tinsel leads
- * Black paint plate
- * Pressed Binding Post Terminal

General Data

Overall Diameters	DxH	312*95mm
RMS Power Handling	RMS	350Watts
Max.Power Handling	MAP	1200Watts
Sentivity 2.83V/1M/1W	SPL	88.5dB
Normal Impedance	OHM	4ohm
Frequency Response	H.Z.	30-120Hz
Net Weight	N.W.	5.1Kgs

Voice and Magnet Parameters

Voice Coil Bobbin	VCB	Black Aluminum
Voice Coil Wire	VCW	Copper
Voice Coil Diameter	VCD	∅ 50.8mm/2"
Coil Bobbin Hight	VBH	55mm/2.17"
Coil Winding Hight	CWH	20.8mm/0.82"
Magnet Material		Ferrite / Y35
Magnet Dimension	M.D	∅ 156mm*25mm
Magnet Weight	M.W.	60 Oz
Magnet Cover	M.C.	Rubber

Voice and Magnet Parameters

DC Resistance	Re	3.2	ohm
Resonant Frequency	Fs	34.32	Hz
Suspension Compliance	Cms	131.82	mm/N
Mechanical Q Factor	Qms	3.65	
Electrical Q Factor	Qes	0.5	
Total Q Factor	Qts	0.44	
Moving Mass	Mms	163.2	gr
Eq.Cas Air Load (Liters)	VAS	56.94	L
Froce Factor	BI	14.95	n/A
Effective X-max (one-way)	Xmax	6.5	mm

Dimension

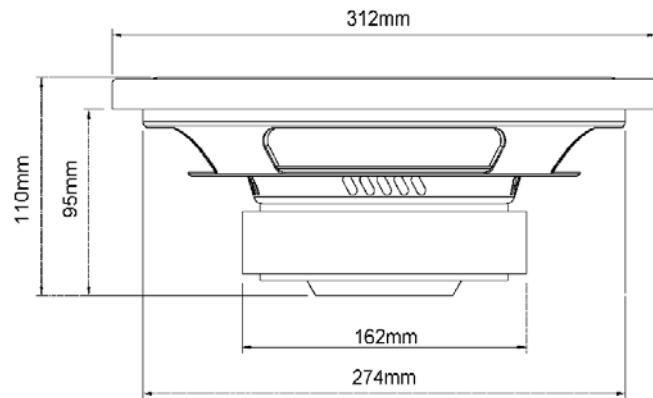

Overall Diameter		312mm
Front Mounting Diameter		300mm
Back Mounting Diameter		274mm
Motor Diameter		162mm
Motor Height		50mm
Gasket Thickness		15.5mm
Mounting Depth		95mm
Overall Height		110mm

*All information listed only for reference