

FOR-X

Model No.: X-312

12inch High Performance Car Subwoofer Chassis



Specifications

- * Stamed Steel frame with white painting
- * Non-pressed paper cone with foam surround
- * Convex IMPP Dust-cap
- * Hi-temp 3inch-4Layers Voice Coil
- * High efficiency Optimized FEA Motor
- * Stiff black progressive Nomex spider with Flat tinsel lead
- * Black Electroplated Vented T plate
- * Pressed Binding Post Terminal

General Data

Overall Diameters	DxH	315*202mm
RMS Power Handling	RMS	800Watts
Max.Power Handling	MAP	1600Watts
Sentivity 2.83V/1M/1W	SPL	85dB
Normal Impedance	OHM	2+2ohm or 4+4ohm
Frequency Response	H.Z.	25-100Hz
Net Weight	N.W.	10.5Kgs

Voice and Magnet Parameters

Voice Coil Bobbin	VCB	Aluminum
Voice Coil Wire	VCW	Copper
Voice Coil Diameter	VCD	∅ 76.5mm/3.01"
Coil Bobbin Hight	VBH	85mm/3.35"
Coil Winding Hight	CWH	35mm/1.38"
Magnet Material		Ferrite / Y35
Magnet Dimension	M.D	∅ 170mm*50mm
Magnet Weight	M.W.	140Oz
Magnet Cover	M.C.	Rubber

Voice and Magnet Parameters

DC Resistance	Re	2+2	3.8+3.8	ohm
Resonant Frequency	Fs	34,6	32,5	Hz
Suspension Compliance	Cms	0,07	0,08	mm/N
Mechanical Q Factor	Qms	5,80	5,32	
Electrical Q Factor	Qes	0,50	0,61	
Total Q Factor	Qts	0,46	0,55	
Moving Mass	Mms	284,3	286,4	gr
Eq.Cas Air Load (Liters)	VAS	27,1	30,5	L
Froce Factor	Bl	22,3	27	n/A
Effective X-max	Xmax	35	35	mm

Dimension

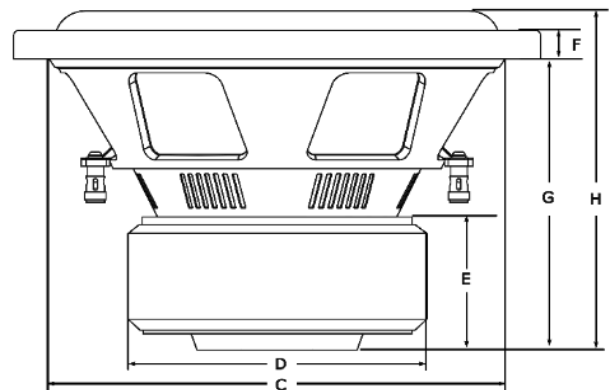
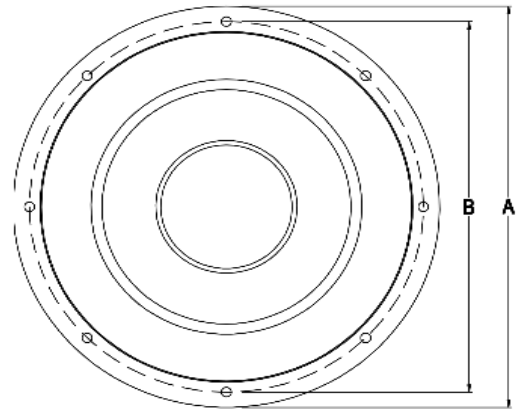

Overall Diameter	A	315mm
Front Mounting Diameter	B	295mm
Back Mounting Diameter	C	275mm
Motor Diameter	D	174mm
Motor Height	E	78mm
Gasket Thickness	F	17mm
Mounting Depth	G	175mm
Overall Height	H	202mm