

FOR-X

Model No.: X-3012

12inch High Performance Car Slim Subwoofer Chassis



Specifications

- * Stamed Steel frame with Black Powder Finish coating
- * Non-pressed paper cone with rubber surround
- * Bow Style IMPP Dust-cap
- * Hi-temp 2.41inch-4Layers Voice Coil
- * High efficiency Optimized FEA Motor
- * Stiff black progressive Poly-cot spider with Round tinsel leads
- * Chromed Vented T plate
- * Pressed Binding Post Terminal

General Data

Overall Diameters	DxH	315*124mm
RMS Power Handling	RMS	250Watts
Max.Power Handling	MAP	500Watts
Sentivity 2.83V/1M/1W	SPL	87dB
Normal Impedance	OHM	4ohm
Frequency Response	H.Z.	25-100Hz
Net Weight	N.W.	4.3Kgs

Voice and Magnet Parameters

Voice Coil Bobbin	VCB	Aluminum
Voice Coil Wire	VCW	Copper
Voice Coil Diameter	VCD	∅ 61.1mm/2.41"
Coil Bobbin Hight	VBH	50mm/1.97"
Coil Winding Hight	CWH	15.3mm/0.6"
Magnet Material		Ferrite / Y35
Magnet Dimension	M.D	∅ 156mm*15mm
Magnet Weight	M.W.	400z
Magnet Cover	M.C.	NO

Voice and Magnet Parameters

DC Resistance	Re	3.2	ohm
Resonant Frequency	Fs	27.8	Hz
Suspension Compliance	Cms	0.21	mm/N
Mechanical Q Factor	Qms	4.2	
Electrical Q Factor	Qes	0.49	
Total Q Factor	Qts	0.44	
Moving Mass	Mms	153.3	gr
Eq.Cas Air Load (Liters)	VAS	77.9	L
Froce Factor	BI	13.2	n/A
Effective X-max	Xmax	8	mm

Dimension

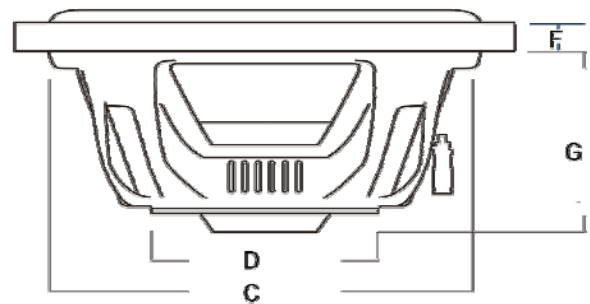
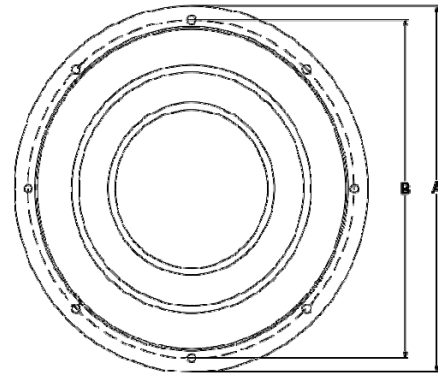

Overall Diameter	A	315mm
Front Mounting Diameter	B	295mm
Back Mounting Diameter	C	271mm
Motor Diameter	D	145mm
Motor Height	E	N/A
Gasket Thickness	F	16mm
Mounting Depth	G	102mm
Overall Height	H	124mm

*All information listed only for reference